

OPERATING INSTRUCTIONS FOR RECORD PLAYER

INITIAL SET-UP:

1. Slowly rotate the Turntable Platter clockwise until the hole in the Platter is directly over the Transit Screw (A) underneath the Platter.
2. Insert a screwdriver into the hole and rotate the Transit Screw (A) clockwise until it is all the way down.
3. Turn the Transit Screw (B) clockwise until it is all the way down.

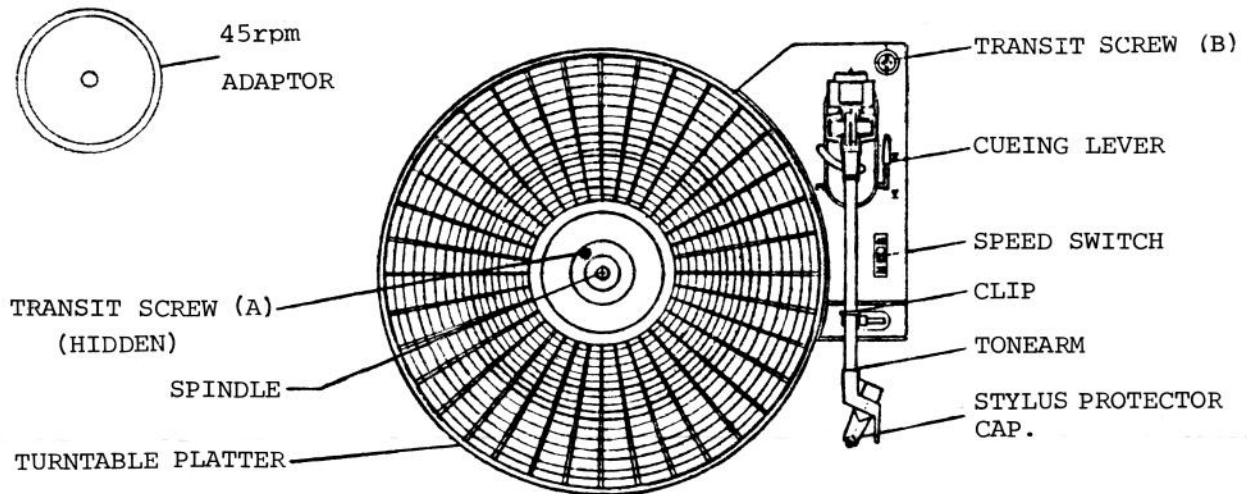

NOTE: Before initial play, unlock the Tonearm and raise the Cueing Lever. -- Move the Tonearm towards the Spindle until the auto return mechanism is engaged. Allow the Tonearm to return to it's rest position and lower -- the Cueing Lever.

USING THE RECORD PLAYER:

1. Unlock the Clip holding the Tonearm and remove the Stylus Protector Cap by pulling it forward.
2. Set the Speed switch to either "33" or "45" depending on the record to be played. To play a 45rpm record, the 45rpm Adaptor must be placed over the Spindle.
3. Place a record on the Turntable Platter.
4. Raise the Cueing Lever and position the Tonearm above the desired track on the record. The Turntable Platter will automatically start rotating.
5. Gently lower the Cueing lever.
6. At the end of the record, the Tonearm will return automatically to it's - rest position and the player will shut off.
7. When not in use, clamp the Tonearm at it's rest position using the Clip.

CAUTION: Manually turning or obstructing the movement of the Turntable Platter may damage the Record Player.